

# Study on Performing an Optimal Chitosan Cased Hydrogel for a New System of Controlled Release of Honokiol

OANA PARTENI<sup>1</sup>, ANDREI VICTOR SANDU<sup>2,3</sup>, CEZAR DORU RADU<sup>1\*</sup>, LACRAMIOARA OCHIUZ<sup>4</sup>, EUGEN ULEA<sup>5</sup>, CATALINA MIHAELA LUCA<sup>6\*</sup>, MARIA BOGDAN<sup>7</sup>, CIPRIAN REZUS<sup>8\*</sup>

<sup>1</sup> Gheorghe Asachi Technical University Iasi, Faculty of Textiles, Leather and Industrial Management, Department of Chemical Engineering, 29 Mangeron Blvd., TEX 1 Building, 700050, Iasi, Romania

<sup>2</sup> Romanian Inventors Forum, 3 Sf.Petru Movila Str., 700089, Iasi, Romania

<sup>3</sup> Gheorghe Asachi Technical University Iasi, Faculty of Science and Engineering Materials, 64 Mangeron Blvd., 700050, Iasi, Romania

<sup>4</sup> Grigore T. Popa University of Medicine and Pharmacy, Faculty of Pharmacy, Department of Pharmaceutical Technology, 16 Universitatii Str., 700115, Iasi, Romania

<sup>5</sup> Ion Ionescu de la Brad University of Agricultural Science and Veterinary Medicine, Department of Plant Science, 3 Mihail Sadoveanu Alley, 700490, Iasi, Romania

<sup>6</sup> Grigore T. Popa University of Medicine and Pharmacy, Faculty of Medicine, Department of Infectious Diseases, 16 Universitatii Str., 700115, Iasi, Romania

<sup>7</sup> University of Medicine and Pharmacy Craiova, Faculty of Pharmacology, Department of Pharmaceutical Technology, 2 Petru Rares Str., 200349, Craiova, Romania

<sup>8</sup> Grigore T. Popa University of Medicine and Pharmacy, Faculty of Medicine, Department of Internal Medicine, 16 Universitatii Str., 700115, Iasi, Romania

*The purpose of this work is the quantitative assessment of the experimental factors necessary to obtain the therapeutic dose of honokiol at the inclusion into a chitosan-based hydrogel. On a 100% cotton knitting fabric, one deposits a hydrogel consisting of chitosan and an ionic cross-linking agent ( $\text{Na}_2\text{SO}_4$ ). The alcohol solution of honokiol is introduced by absorption into the hydrogel deposited on the knitting fabric. The knitting fabric with hydrogel and honokiol is immersed into a perspiration kit at 37°C to determine the drug release. One has performed experiments according to a 2<sup>3</sup> order factorial central compositional program.*

**Keywords:** honokiol, therapeutic dose, drug release, optimization

Besides the protection and heat insulation of the subject against the environment, medical textiles can play a therapeutic role or can maintain a climate without pathogen agents [1-3]. As support for hydrogel one uses interlock knitting, i.e. the usual structure of the textile articles meant for under linen. Honokiol (HK) is a medicine extracted from the bark of *Magnolia officinalis*, *Magnolia obovata* or *Magnolia biondi* trees. In Asia this is used as raw material in traditional medicine and has been studied intensely, being the subject of many communications [4-9]. As a plant, magnolia has a content rich in alkaloids, coumarines, flavonoides, lignans, neolignans, phenyl propanoides and terpenoides. The products important and efficient in terms of medical action are honokiol (2-(4-hydroxy-3-prop-2-enyl-phenyl)-4-prop-2-enyl-phenol), magnolol (4-Allyl-2-(5-allyl-2-hydroxy-phenyl)phenol), obovatol (5-Prop-2-enyl-3-(4-prop-2-enylphenoxy)benzene-1,2-diol) and 4-O-methyl honokiol [10, 11]. Scheme 1 illustrates the chemical structure of HK.

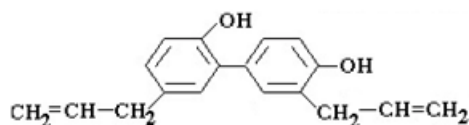

Scheme 1  
Chemical structure of HK

Honokiol is used in skin cancer therapy [12], having also an anti-inflammatory, anxiolytic and anti-depressive effect, especially for patients with Alzheimer disease; it has also

an anti-convulsive and anti-oxidizing effect, determines the smooth muscle relaxation [13] and has an anti-fungal activity. At skin level, both magnolol and the extract of *Magnolia officinalis* in methanol present remarkable inhibitory effects in the development of skin tumors [14]. Communications show that the extracts from *Magnolia* genus have an especially reduced toxicity and negligible adverse effects [15].

## Experimental part

### Materials

Honokiol was purchased as a white powder from pharmacy. Fluka supplied Sodium sulphate and highly viscous chitosan (CS). Sigma Aldrich delivered L-histidine monohydrochloride monohydrate and NaCl and  $\text{NaH}_2\text{PO}_4 \cdot 12\text{H}_2\text{O}$ .

As a textile support one has used interlock knitting samples made of 100% cotton yarns with yarn count Nm = 60/1; the samples with the dimensions 5 × 5 cm were cleaned through alkaline boiling and bleaching with hydrogen peroxide.

### Equipment

HK concentration is determined with a Nanodrop equipment (Nano Drop spectrophotometer ND- 1000, 2007 from NanoDrop Technologies Inc.) at the wavelength  $\lambda = 291 \text{ nm}$ .

\* email: rcezar2010@yahoo.com;

catalina\_luca2006@yahoo.com; ciprianrezus@yahoo.com

**Table 1**  
ABSORBANCE VALUES IN TERMS OF TIME FOR HK RELEASE

Sample	1h	3h	6h
1	0.114	0.030	0.004
2	0.115	0.027	0.005
3	0.108	0.034	0.004
4	0.124	0.030	0.008
5	0.112	0.026	0.007
6	0.111	0.024	0.010
7	0.124	0.029	0.008
8	0.118	0.023	0.012
9	0.133	0.036	0.009
10	0.130	0.035	0.012
11	0.125	0.026	0.012
12	0.132	0.037	0.012
13	0.130	0.048	0.016
14	0.123	0.030	0.009
15	0.131	0.036	0.015
16	0.138	0.032	0.007
17	0.123	0.028	0.008
18	0.135	0.036	0.010
19	0.128	0.027	0.009
20	0.129	0.026	0.008

calculated in terms of CS amount used in each formula. One measure the absorbance of the solution remained after taking out the material samples [16]. From the equation of the straight line of the calibration curve, one calculates the quantity of enclosed drug. After 24 h, the samples are removed from the solution, dried at the environment temperature and then included in the solution of perspiration kit [17] at a liquor ratio of 1:40 and a temperature of 37°C. The material samples are kept in the perspiration kit solution for 1, 3, 6, 12 and 24 h respectively, being dried after each period. The utilized perspiration kit mimes the pH condition of the human derma (pH = 5.5) according to ISO 105-E04-2008. The chemical composition of the perspiration kit is L-Histidine monohydro chloride monohydrate (w/v) 0.05%, at a liquor ratio of 1:100. One measures the absorbance of each solution. Table 1 presents the obtained values.

After 6 h, the solutions absorbance becomes negligible. As one can see from the values presented in table 1, the drug release occurs during the first three hours, a *burst effect* being obtained. From the equation of the calibration curve, one calculates the amount of the released drug.

Factor	UM	Code factor	$x_i$ min- $x_i$ max	$x_{i0}$	-1.682	-1	0	+1	+1.682
Time of immersion	H	$X_1$	3-24	13.5	3	7.25	13.5	19.75	24
CS amount	G	$X_2$	0.6-2.0	10.3	0.6	0.88	1.3	1.72	2
CS in solution	g/L	$X_3$	6-10	8	6	6.81	8	9.19	10

**Table 2**  
FIELDS OF VARIATION AND CODING OF INDEPENDENT VARIABLES

#### Drug inclusion and release

One prepares a basic solution that contains 30 mg HK in 100 mL solution of ethyl alcohol (25%) to obtain the calibration curve. For the basic solution, one determines at the wavelength of 291 nm the absorbance, equal to 0.540. One prepares the hydrogel solution in acetic acid medium depending on the formula established according to the experimental program. One introduces the knitting samples in the hydrogel solution at the environment temperature. After keeping the textile sample for 24 h in hydrogel solutions, this is taken out and suspended on a device to remove the hydrogel excess.

Each knitting sample with hydrogel is introduced in 20 mL of drug solution with a concentration of 0.03% for 24 h, under stirring, at environmental temperature. The drug solution also contains natrium sulphate in a concentration

Table 2 illustrates the limits of variation of the independent parameters and the attached codes.

#### Experimental plan concerning drug inclusion and release

Hydrogel application on the textile material influences the amount of included and released drug respectively; in order to establish the optimum treatment formula, the experiments have been carried out according to a  $2^3$  order factorial rotatable compositional central program. One has considered as independent variables: duration of maintaining the samples immersed in CS solution,  $x_1$  (h); CS amount deposited on the textile material,  $x_2$  (g), and the CS amount in the solution,  $x_3$  (g/L). The optimization criteria or the target functions, also called dependent variables, were as follows: the amount of included drug,  $Y_1$  (mg HK/g mat) and the amount of released drug  $Y_2$  (mg HK/g mat). Table 3 presents the experimentally obtained values.

Test number	$x_1$		$x_2$		$x_3$		$Y_1$	$Y_2$
	code	real	code	real	code	real		
1	-1	7.25	-1	0.88	-1	6.81	1.58	1.41
2	+1	19.75	-1	0.88	-1	6.81	1.88	1.48
3	-1	7.25	+1	1.72	-1	6.81	1.79	1.45
4	+1	19.75	+1	1.72	-1	6.81	1.89	1.61
5	-1	7.25	-1	0.88	+1	9.19	1.65	1.43
6	+1	19.75	-1	0.88	+1	9.19	1.75	1.52
7	-1	7.25	+1	1.72	+1	9.19	1.81	1.54
8	+1	19.75	+1	1.72	+1	9.19	1.85	1.68
9	-1.682	3	0	1.3	0	8	1.84	1.62
10	+1.682	24	0	1.3	0	8	2.01	1.77
11	0	13.5	-1.682	0.6	0	8	1.61	1.35
12	0	13.5	+1.682	2.0	0	8	2.20	1.80
13	0	13.5	0	1.3	-1.682	6	1.62	1.51
14	0	13.5	0	1.3	+1.682	10	2.25	1.83
15	0	13.5	0	1.3	0	8	1.86	1.69
16	0	13.5	0	1.3	0	8	1.86	1.69
17	0	13.5	0	1.3	0	8	1.76	1.58
18	0	13.5	0	1.3	0	8	1.85	1.68
19	0	13.5	0	1.3	0	8	1.80	1.64
20	0	13.5	0	1.3	0	8	1.86	1.69

**Table 3**  
EXPERIMENTAL PLAN AND OBTAINED RESULTS

After performing the experiments, one establishes if the variables chosen as independent variables have a significant influence on the chosen dependent variables (target function). One compares thus the selection corresponding to the set of experiments with that corresponding to the experiments in the central point. The form of the empiric 2<sup>m</sup> order rotatable compositional central model, which represents the basis of the planning, corresponds to the following relation:

$$Y = b_0 + \sum_{i=1}^k b_i X_i + \sum_{j,i=1}^m b_{ji} X_i X_j \quad (1)$$

where:

Y- the response function or dependent variable or target function;

$x_i, x_j$ - coded variables of the studied process, independent variables;

$b_0, b_i, b_j, b_{ij}$ - model's coefficients.

The general form of the mathematical model for three independent variables ( $m=3$ ) is:

$$Y = b_0 + b_1 X_1 + b_2 X_2 + b_3 X_3 + b_{12} X_1 X_2 + b_{13} X_1 X_3 + b_{23} X_2 X_3 + b_{11} X_1^2 + b_{22} X_2^2 + b_{33} X_3^2 \quad (2)$$

One determines the coefficients of the target function through the method of the least squares [18, 19] using the matrix relation bellow [20]:

$$b = (X^T X)^{-1} X^T Y \quad (3)$$

where:

b - column matrix of the regression coefficients,  $b_i$ ;

X - matrix with coded variables  $x_i$ ;

Y - column matrix of the experimental values for the target function,  $Y_i$ ;

Table 4 presents the values of the coefficients for the two proposed target functions ( $Y_i$ ).

One has tested the significance of the coefficients of the target function using the *t* (Student) test, eliminating the insignificant ones; the remained significant coefficients are presented in table 5 and correspond to the equations of the mathematical model. When applying the *t* (Student)

**Table 4**  
VALUES OF THE REGRESSION COEFFICIENTS ( $Y_i$ )

Coefficient	Y <sub>1</sub>	Y <sub>2</sub>
b <sub>0</sub>	1.8369	1.6662
b <sub>1</sub>	0.0605	0.0507
b <sub>2</sub>	0.0107	0.0890
b <sub>3</sub>	0.0719	0.0571
b <sub>12</sub>	-0.0325	0,0200
b <sub>13</sub>	-0.0325	0.0250
b <sub>23</sub>	0.0050	0.0100
b <sub>11</sub>	0.0007	-0.0165
b <sub>22</sub>	-0.0063	-0.0589
b <sub>33</sub>	0.0043	-0,0253

Coefficient	Y <sub>1</sub>	Y <sub>2</sub>
b <sub>0</sub>	1.8369	1.662
b <sub>1</sub>	0.0605	0.0507
b <sub>2</sub>	0.01077	0.0890
b <sub>3</sub>	0.07719	0.0571
b <sub>12</sub>	-0.0325	0.020
b <sub>13</sub>	-0.0325	0.0025
b <sub>23</sub>	0.0050	0.0100
b <sub>11</sub>	0.0007	-0.0165
b <sub>22</sub>	-0.0063	-0.0589
b <sub>33</sub>	0.0043	-0.0253

**Table 5**  
VALUES OF THE T TEST  
AND COEFFICIENTS'  
VALUES OF FUNCTIONS  
Y<sub>1</sub> AND Y<sub>2</sub>

test, one considers the following: - for a coefficient  $b_i$ , the relation is:  $t_{bi \text{ calc.}} = b_i/s$  (the standard deviation of  $b_i$ ); for a coefficient  $b_{ij}$ , the relation is:  $t_{bij \text{ calc.}} = b_{ij}/s$  (standard deviation of  $b_{ij}$ ). If  $|t_{calc.}| > t^* b \text{ crit.}$  (the value from the table or the critical value, depending on the degrees of freedom ( $f_1 = 10$  and  $f_2 = 1$ ) and the chosen significance threshold ( $\alpha = 0.05$ ), one admits that, at the chosen significance threshold, the corresponding coefficient is significant, therefore the corresponding term will remain in the regression equation. Otherwise, one can neglect the corresponding term. Table 5 presents the insignificant values through a value cut by a horizontal line).

As the result of the application of the *t* (Student) test, the insignificant coefficients were eliminated. One obtains thus the equations, which describe the dependencies of the proposed independent variables of the process for obtaining the hydrogel, as well as the optimization criterion or the considered dependent variable (the amount of included and released drug respectively):

$$Y_1 = 1.8369 + 0.0605X_1 + 0.01077X_2 + 0.0719X_3 - 0.0325X_1X_2 - 0.0325X_1X_3 + 0.0007X_1^2 + 0.0043X_3^2 \quad (4)$$

$$Y_2 = 1.662 + 0.0507X_1 + 0.0890X_2 + 0.0571X_3 + 0.020X_1X_2 + 0.0025X_1X_3 + 0.0165X_1^2 + 0.0253X_3^2 \quad (5)$$

One has used the Fisher test to find the model adequacy. The regression dispersion as compared to the experimental data is computed with the relation:

$$F_{calc} = \frac{(n-1) \sum_{i=1}^n (Y_{ei} - \bar{Y}_e)^2}{(k-1) \sum_{i=1}^n (Y_{eki} - \bar{Y}_{ek})^2} \quad (6)$$

where:

$Y_{ei}$  - experimental values of the dependent variable;

$\bar{Y}_e$  - mean value of the dependent variable;

$Y_{eki}$  - experimental values of the dependent variable from the program center;

$\bar{Y}_{ek}$  - mean values of the experimental values from the program center;

$n = 20$  - the total number of experiments from the experimental matrix;

$k = 6$  - number of experiments from the program center.

The calculated value of *F* is compared with the value from the table,  $F_{tab}$  ( $\alpha = 0.05$ ;  $f_1 = 10$ ,  $f_2 = 1$ ).

If  $F_{calc.} < F_{tab}$ , the mathematical model is adequate (95% probability) and the concordance between the mathematical model and the experimental data is statistically accepted for the significance level  $A = 0.05$ .

Function	$\sum_{i=1}^n (Y_{ei} - \bar{Y}_e)^2$	$\sum_{i=1}^n (Y_{ek} - \bar{Y}_{ek})^2$	F calc	F <sub>tab</sub>	F <sub>calc</sub> < F <sub>tab</sub>
Y <sub>1</sub>	10.57	0.00445	237.52	42	Adequate
Y <sub>2</sub>	7.80	0.0495	157.57		Adequate

**Table 6**  
VALUES OBTAINED FOR MODEL ADEQUACY

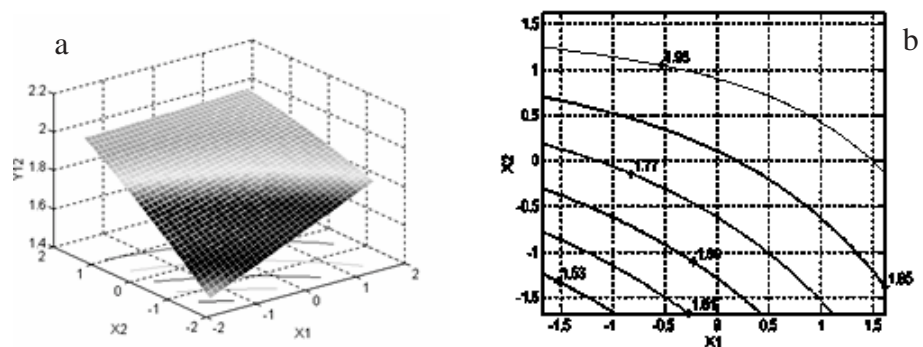

Fig. 1. Influence of independent variables  $x_1$  and  $x_2$  on the amount of included HK ( $Y_1$ ):  
a. response surfaces;  
b. constant level curves

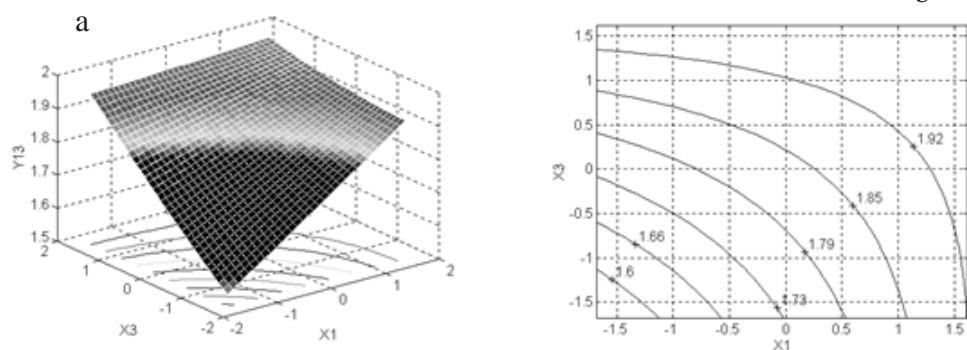

Fig. 2. Influence of independent variables  $x_1$  and  $x_3$  on the amount of included HK ( $Y_1$ )  
a. response surfaces;  
b. constant level curves

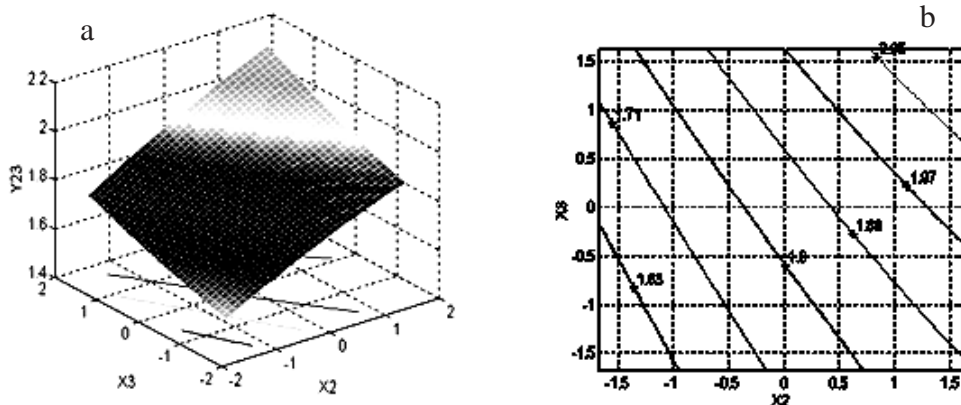

Fig. 3. Influence of independent variables  $x_2$  and  $x_3$  on the amount of included HK ( $Y_1$ )  
a. response surfaces;  
b. constant level curves

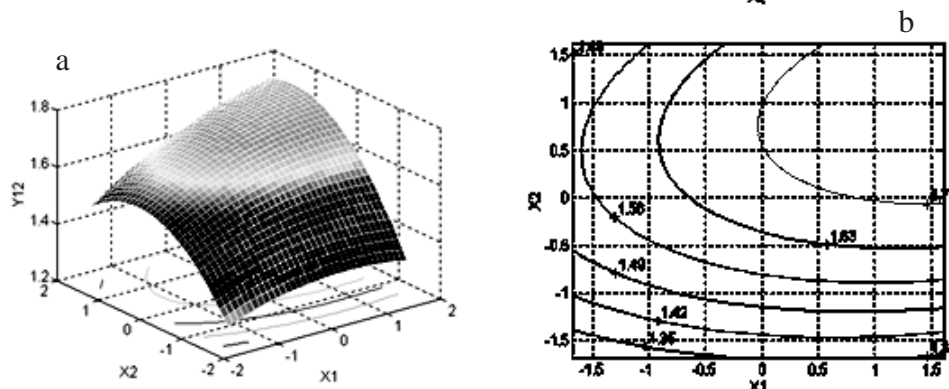

Fig. 4. Influence of independent variables  $x_1$  and  $x_2$  on the amount of released HK ( $Y_2$ )  
a. response surfaces;  
b. constant level curves

Table 6 presents the adequacy of the two proposed mathematical models, as compared to the experimental values ( $n = 20$  and  $k = 6$ ).

The proposed mathematical model is represented graphically using the Matlab program. One computes and plots graphically the values of the target function by varying a single independent variable  $Y_i = \hat{Y}_i(x_i)$ , while the other two are maintained in the center of the experimental

domain ( $x_j = 0$ ), pursuing the variation of the dependent variable values. Then, one computes and plots graphically the values of the target function obtained by maintaining an independent variable at its value from the center of the experimental domain ( $x_i = 0$ ), the other two taking values within the experimental domain considered as adequate. Then one plots curves in space and plane, in order to analyze and interpret the obtained values of the target function (dependent variable). Finally, one determines the optimum

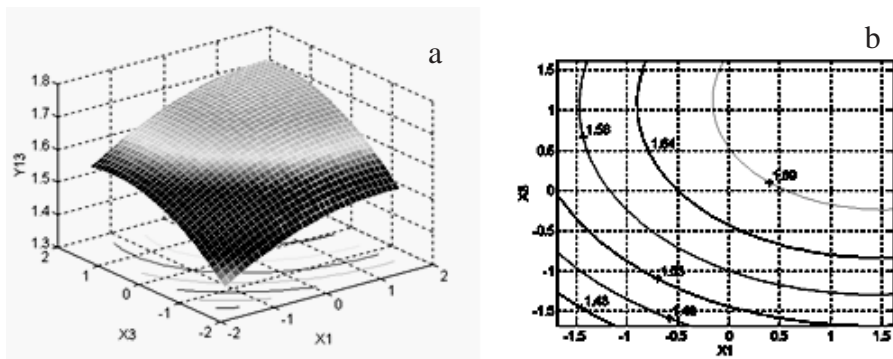

Fig. 5. Influence of independent variables  $x_1$  and  $x_3$  on the amount of released HK ( $Y_2$ )  
a. response surfaces; b. constant level curves

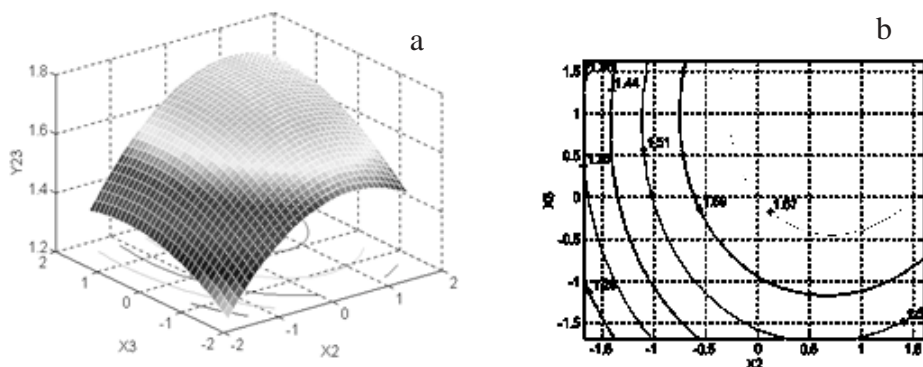

Fig. 6. Influence of independent variables  $x_2$  and  $x_3$  on the amount of released HK ( $Y_2$ )  
a. response surfaces; b. constant level curves

values of the independent variables and the target function and, by transforming the coded values in real values, one obtains the values of the working parameters to reach the pursued optimum values.

By analyzing the variation of one parameter, while the other two are maintained constant in the center of the experimental domain, one plots the variation curves presented in figures 1- 6.

## Conclusions

Following the obtained results, one obtains as optimum formula: 0.6 mg CS, time of maintaining in CS solution 13.5 h; CS concentration in the treatment solution 6 g/L. As the result of the performed determinations, one obtains the therapeutic dose ( $1.25 \div 1.67$  mg HK/25 cm<sup>2</sup>) through the utilization of hydrogel formulas.

## References

- PARTENI, O., Ph.D. Thesis, Gheorghe Asachi Technical University, Iasi, 2015.
- RADU, C.D., PARTENI, O., OCHIUZ, L., *J. Control. Rel.*, **224**, 2016, p. 146.
- POPOVICI, R., VLASE, G., VLASE, T., SUTA, L.M., POPOIU, C., LEDETI, I., *Rev. Chim. (Bucharest)*, **66**, no.7, 2015, p. 1046.
- CHOI, N.H., CHOI, G.J. MIN, B.S., JANG, K.S., CHOI, Y.K., KANG, M.S., *J. Appl. Microbiol.* **106**, 2009, p. 2057.
- LEE, Y.K., YUK, D.Y., KIM, T.I., KIM, Y.K., KIM, K.T., KIM, K.H., *J. Nat. Med.* **63**, 2009, p. 274.
- PARTENI, O., RADU, C.D., MURESAN, A., SANDU, A.V., OPROIU, L.C., CIOBANU, L., SANDU, I.G., *Rev. Chim. (Bucharest)*, **66**, no. 11, 2015, p. 1780.
- GHIORGHITA, C.A., BUCATARIU, F., MIHAI, M., DRAGAN, E.S., *Mat.Plast.*, **52**, no 1, 2015, p. 51.
- GHIORGHITA, C.A., BUCATARIU, F., HITRUC, G., MIHAI, M., DRAGAN, E.S., *Mat. Plast.*, **51**, no 3, 2014, p. 323.
- POPESCU, V., SANDU, I.C.A., POPESCU, G., *Rev. Chim. (Bucharest)*, **67**, no. 4, 2016, p. 768.
- LEE, Y., LEE, Y.M., LEE, C.K., JUNG, C.K., HAN, S.B., HONG, J.T., *Pharmacol. Therap.*, **130**, 2011, p. 157.
- BANG, K.H., KIM, Y.K., MIN, B.S., NA, M.K., RHEE, Y.K., LEE, J.P., *Arch. Pharm. Res.*, **23**, 2000, p. 46.
- KONOSHIMA, T., KOZUKA, M., TOKUDA, H., NISHINO, H., IWASHIMA, A., HARUNA, M., *J. Nat. Prod.*, **54**, 1991, p. 816.
- LIM, Y., KWON, J.S., KIM, D.W., LEE, S.H., PARK, R.K., LEE, J.J., *Atherosclerosis*, **210**, 2010, p. 372.
- HIBASAMI, H., ACHIWA, Y., KATSUZAKI, H., IMAI, K., YOSHIOKA, K., NKANISHI, K., *Int. J. Mol. Med.*, **2**, 1998, p. 671.
- LIU, Z., ZHANG, X., CUI, W., LI, N., CHEN, J., WONG, A.W., *Regul. Toxicol. Pharmacol.* **49**, 2007, p. 160.
- PARTENI, O., RADU, C.D., MURESAN, A., POPA, M., OCHIUZ, L., SANDU, A.V. AGAFITEL, GH., ISTRATE, B., MUNTEANU, C., *Rev. Chim. (Bucharest)*, **66**, no. 10, 2015, p. 1595.
- KULTONG, K., SRISUNG, S., BOONPAVANITCHAKUL, K., KANGWANSUPAMONKON, W., MANIRATANACHOTE, R., *Part. Fibre Toxicol.*, **7**, no. 8, 2010, p.1.
- PERJU, S., STANESCU, I., *Rev. Chim. (Bucharest)*, **66**, no.6, 2015, p. 886.
- POPESCU, V., SANDU, I.G., VASLUIANU, E., SANDU, I., MANEA, L.R., CAMPAGNE, C., *Rev. Chim. (Bucharest)*, **65**, no. 12, 2014, p. 1439.
- LIU, Y., HE, J.-H., *International Journal of Nonlinear Sciences and Numerical Simulation*, **8**, no.3, 2007, p. 393

Manuscript received: 14.09.2015